

25°	0,5 L + 824	L + 541
30°	0,5 L + 880	L + 479
35°	0,5 L + 753	L + 440
40°	0,5 L + 705	L + 398
45°	0,5 L + 648	L + 360
P	b	×c
inclinação	L - comprimento	

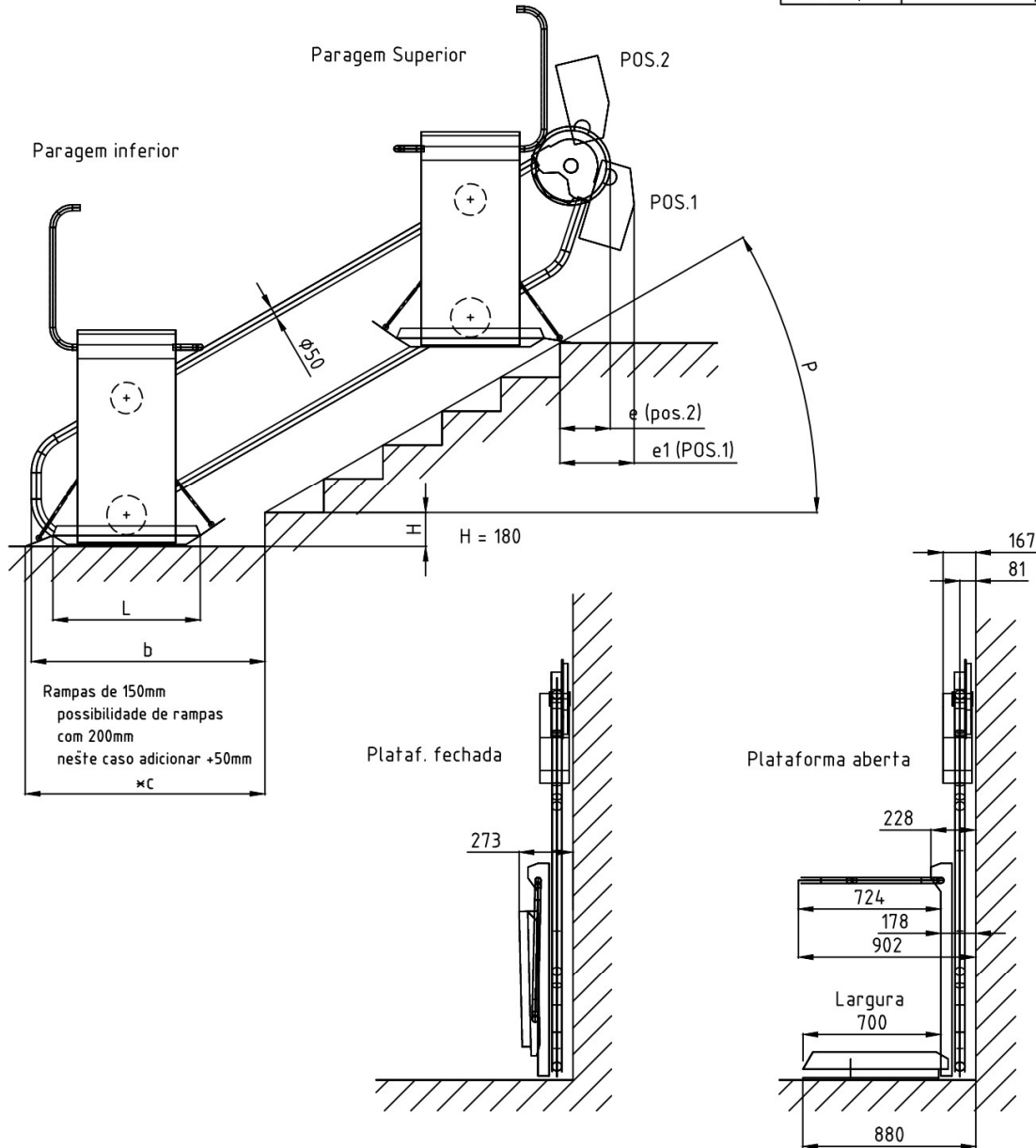

25°	1255	1291	234	399	1330	1441	234	399	1380	1541	280	399
30°	1199	1229	253	376	1274	1379	253	376	1324	1479	243	376
35°	1128	1190	212	361	1203	1340	212	361	1253	1440	212	361
40°	1080	1148	260	350	1155	1298	260	350	1205	1398	258	350
45°	1023	1110	310	338	1098	1260	310	338	1148	1360	310	338
P	b	×c	e	e1	b	×c	e	e1	b	×c	e	e1
inclinação	L = 750				L = 900				L = 1000			

Sujeito a alterações !

Curva a 90°

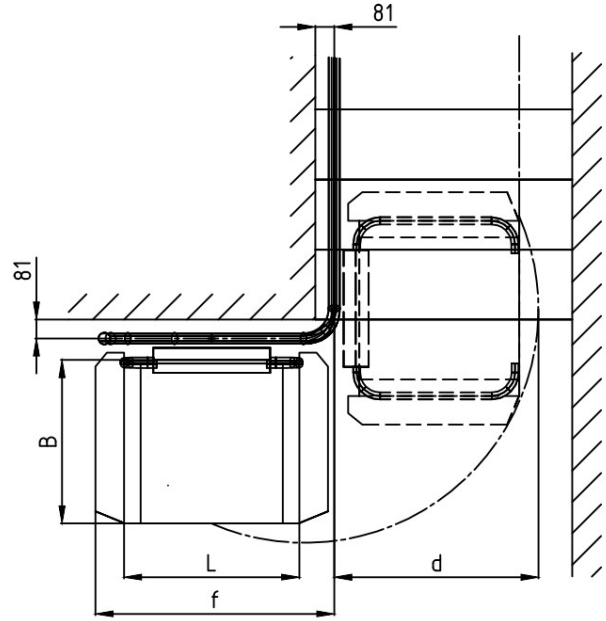
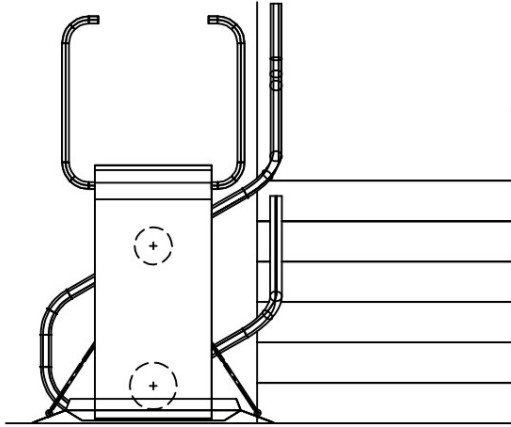

Curva a 180°
estacionam. inferior

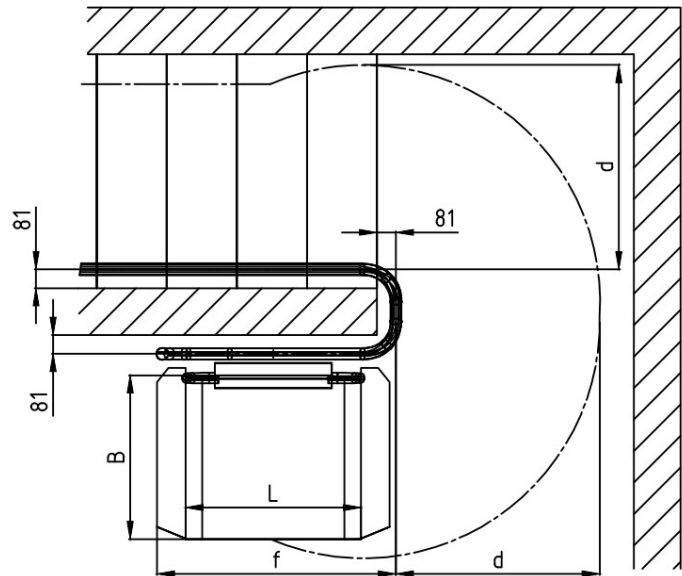
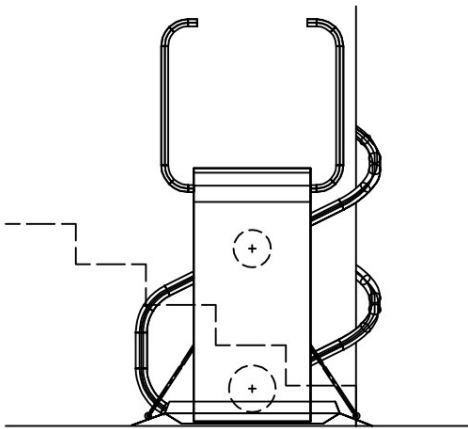

Plataforma Comp. L	Rampas acesso	Largura Plataforma - B									f
		600	640	670	700	740	770	800	900	1000	
750	150	789	823	848	874	909	935	962	1054	1149	1050
	200	812	845	870	895	929	955	981	1070	1160	1150
900	150	832	864	889	914	947	973	998	1085	1174	1200
	200	857	888	912	937	970	995	1020	1105	1193	1300
1000	150	862	894	918	942	975	1000	1023	1110	1197	1300
	200	889	919	943	966	998	1023	1047	1131	1217	1400

Sujeito a alterações !

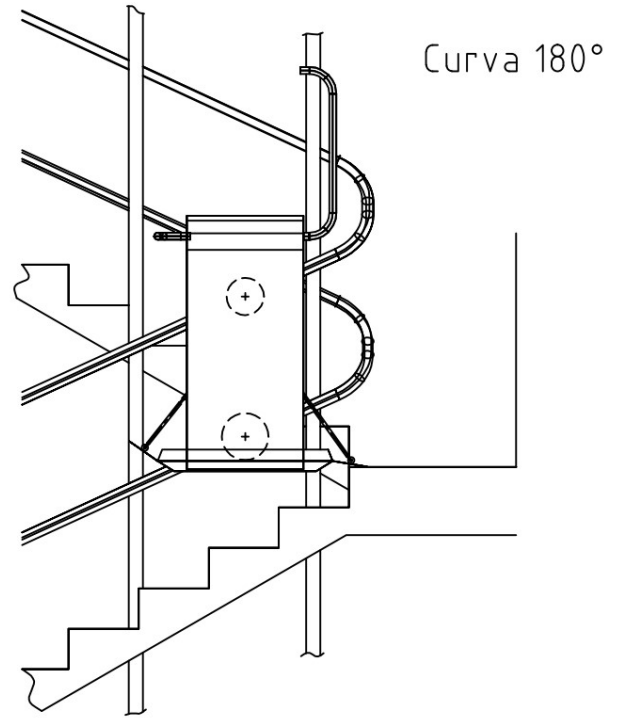
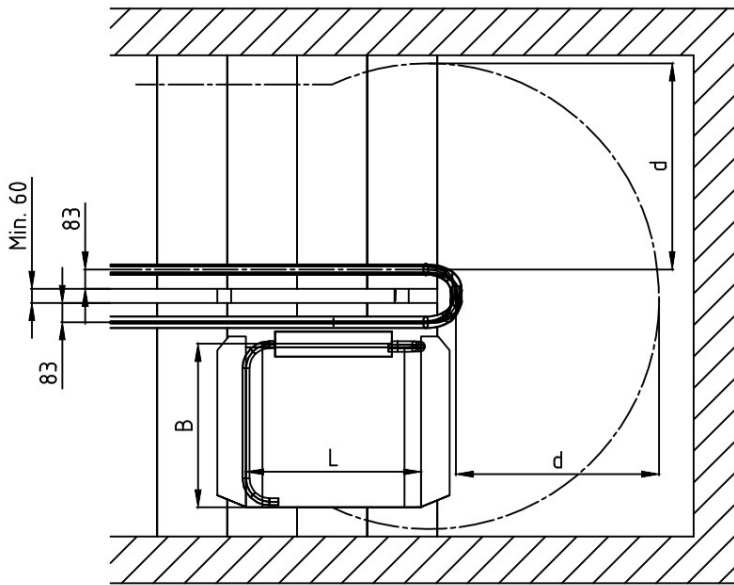

Estacionamento inferior apertado

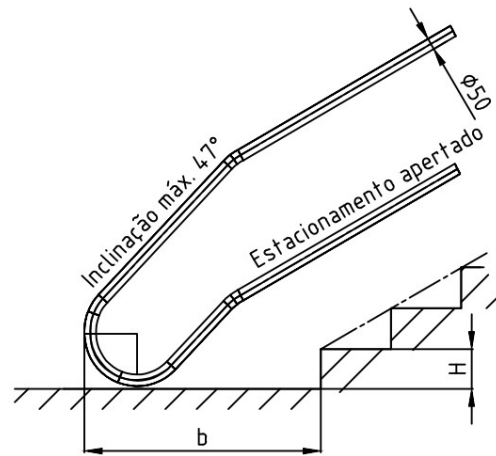
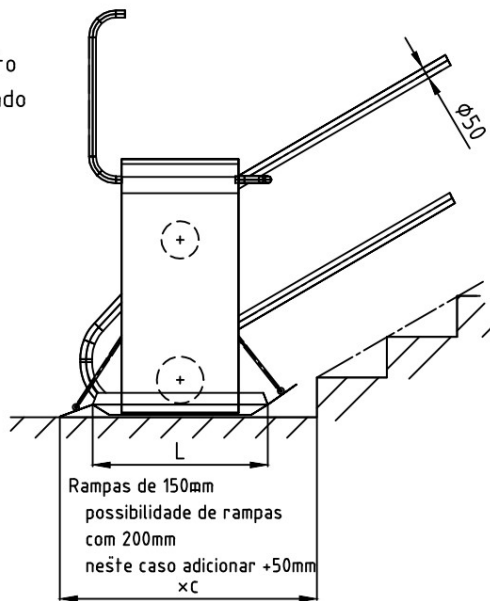

Inclinação máxima de 4,7°								
150	994	1081	1069	1231	1119	1331	0,5 L + 619	L + 331
160	1003	1090	1078	1240	1128	1340	0,5 L + 628	L + 340
170	1012	1099	1087	1249	1137	1349	0,5 L + 637	L + 349
180	1021	1108	1096	1258	1146	1358	0,5 L + 646	L + 358
190	1030	1117	1105	1267	1155	1367	0,5 L + 655	L + 367
200	1039	1226	1114	1276	1164	1376	0,5 L + 664	L + 376
H altura 1º degrau	b	*c	b	*c	b	*c	b	*c
	L = 750		L = 900		L = 1000		L = especial grande	

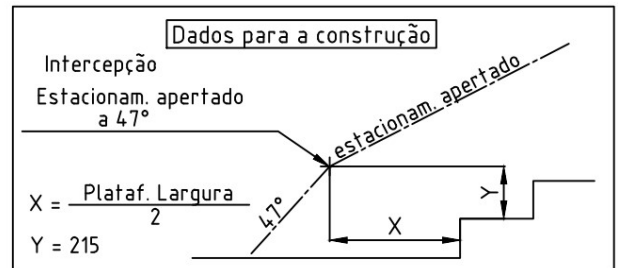

Sujeito a alterações !